

GHG-VH8 Combination Hinge

Features

- Modular hinges with built-in damper, spring or torque
- Various motion types (soft-close, self-opening, etc.) can be achieved with combined use of available hinge types
- For hinges with built-in springs, the spring tension can be adjusted with a hex key
- Passed 50,000 life cycle test

Notes

- Operating temperature: 0°C ~ 40°C
- Ensure hinge shafts are aligned during installation



Hinge Motions (For Top-Opening Lids)

	Part Built-in	Without Part Built-in	Damper	Spring (self-opening)	Spring (self-closing)	Torque
			Soft-close	Self-opening	Self-closing	Free stop
Motions						
		Freely opens and closes as normal hinges.	Slowly closes.	Always tries to open.	Always tries to close.	Stops at any position.
Possible Combinations (built-in unit)	Without Part Built-in	Yes	Yes	Yes	Yes	Yes
	Damper	Yes	Yes	Yes	Yes	No
	Spring (self-opening)	Yes	Yes	Yes	No	It depends
	Spring (self-closing)	Yes	Yes	No	Yes	It depends
	Torque	Yes	Yes	No	It depends	It depends

To carry out thorough testing before using as performance of above combinations may vary depending on door size and weight

Combination Example

- Spring (self-closing) + Damper (lateral-opening)

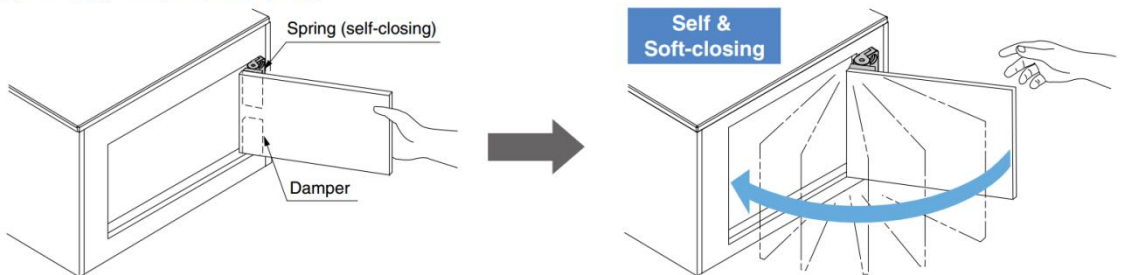

- Spring (self-opening) + Damper (using top-opening lid with a push latch)

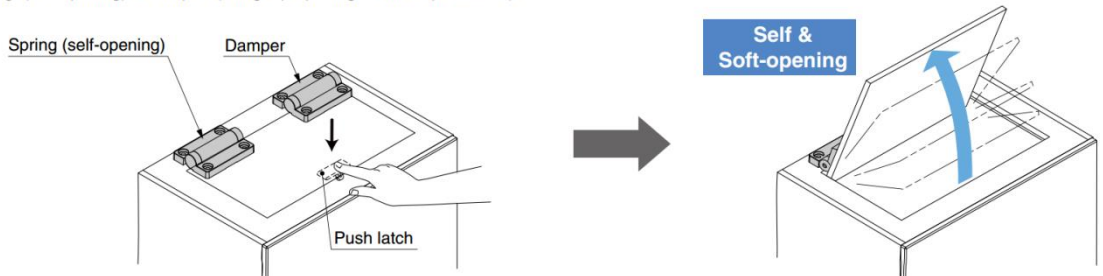

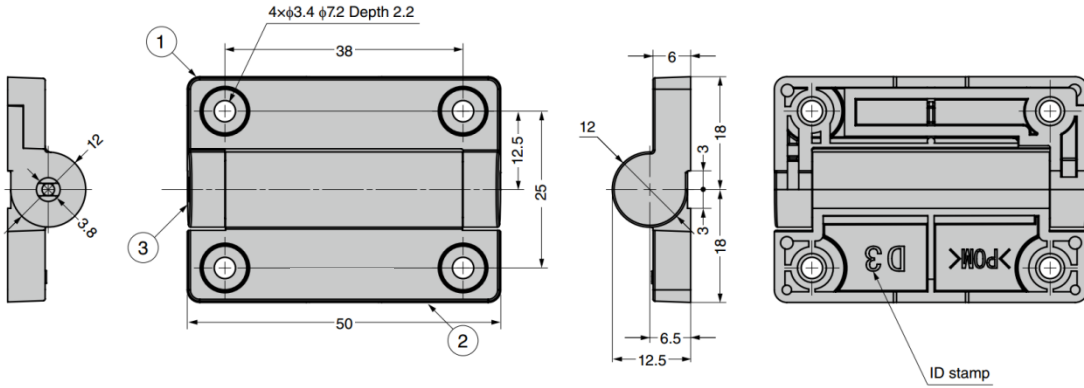

No.	Part Name	Material	Colour
①	Bracket A	POM	Black, White
②	Bracket B		
③	Bracket C		
-	Damper URD8-3	POM, etc.	-
-	Spring Unit URS8	-	-
-	Torque Unit URT8	-	-

Lateral-opening door weight: max. 810g

Reference door size: W300 × H450 × t5 mm

Acrylic plate, density 1.2 g/cm³

Part No.	Part Built-In	ID Stamp	Colour	Torque (per piece)		Opening Angle
GHG-VH8-N-BL	-	N	Black	-	-	270°
GHG-VH8-N-WT			White	-	-	
GHG-VH8-D3-BL	Damper	D3	Black	0.022 ~ 0.038 N.m	0.22 ~ 0.39 kgf.cm	
GHG-VH8-D3-WT			White			
GHG-VH8-OP-BL	Spring (Self-Opening)	OP	Black	※	※	
GHG-VH8-OP-WT			White			
GHG-VH8-CL-BL	Spring (Self-Closing)	CL	Black	※	※	
GHG-VH8-CL-WT			White			
GHG-VH8-T15-BL	Torque	T1	Black	0.15 ± 0.05 N.m	1.53 ± 0.51 kgf.cm	
GHG-VH8-T15-WT			White			
GHG-VH8-T35-BL		T3	Black	0.35 ± 0.1 N.m	3.57 ± 1.02 kgf.cm	
GHG-VH8-T35-WT			White			

※ Increased by 0.0153 N.m (0.16 kgf.cm) by adjusting the spring tension. The initial value of the spring tension is 0 N.m

How to Adjust Spring Tension

● Spring (self-opening)

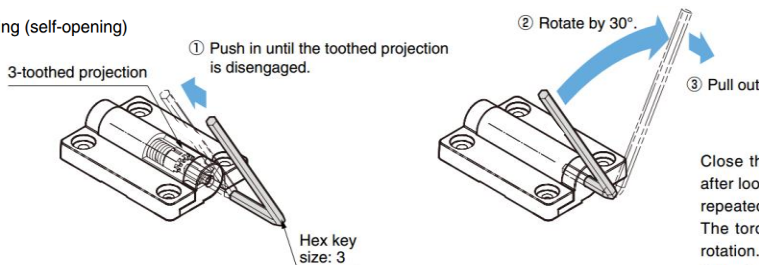

Close the lid, and check if the lid can be opened smoothly after loosening your hand(s). If the spring tension is not enough, repeated steps ① ~ ③.

The torque will be increased by 0.0153N·m at each 30° of rotation. Generally no more than 4 times (120°) are required. To restore to the initial state, rotate in the direction opposite to above.

● Spring (Self-closing)

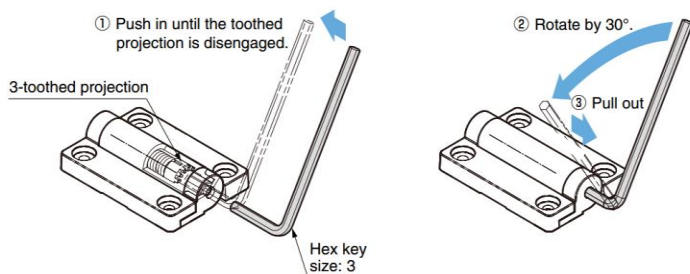

Open the lid and check if the lid can be closed smoothly after loosening your hand(s). If the spring tension is not enough, repeated steps ① ~ ③.

The torque will be increased by 0.0153N·m at each 30° of rotation. Generally no more than 4 times (120°) are required. To restore to the initial state, rotate in the direction opposite to above.